

Instructions for 8495 valve repair kits

1.5" Valve 70212001 uses kit 70212RP1

2.0" Valve 70213001 uses kit 70213RP1

2.5" Valve 70215001 uses kit 70215RP1

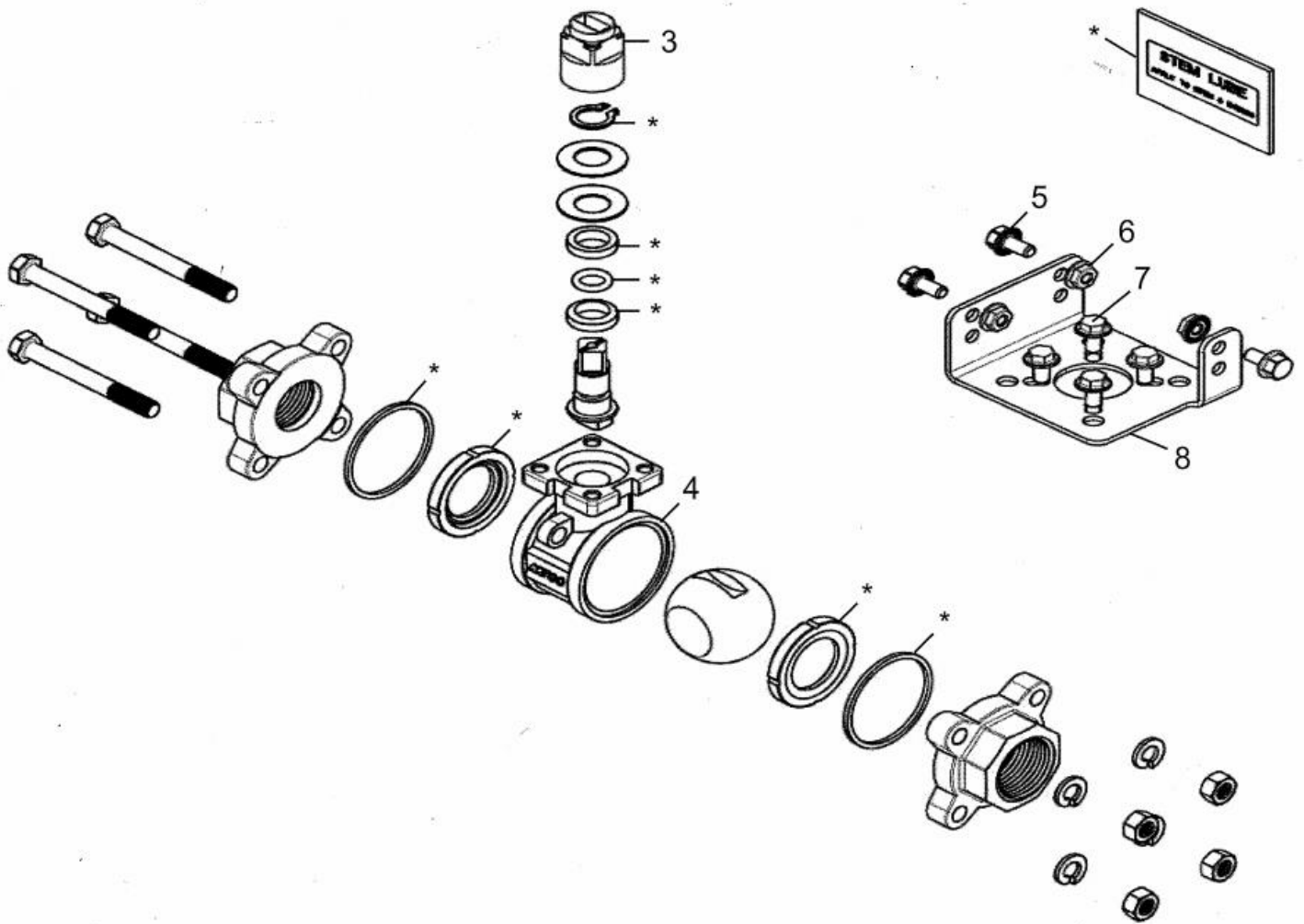

Replacement parts included in repair kit *

INSTRUCTIONS:

1. Place valve in the closed position.
2. Disconnect power to the valve's electric actuator.
3. Remove actuator bolts & nuts (Items 5 & 6), lift off actuator and set aside.
4. Remove actuator adaptor (Item 3) and set aside.
5. Remove actuator bracket bolts and nuts (Item 7) and set bracket (Item 8) aside.
6. Remove valve body bolts (F), nuts (M), & lock washers and set End Caps (G) aside.
7. Remove and discard valve body seals (*H) and valve seats (*J).
 - a. In the 2.0" kit 70213RP1 there are no body seals (*H) the valve seats (*J) have an OD flange that serves as the body seals.
8. Remove valve ball (K) and set aside.
9. Remove & discard actuator shaft retainer ring (*A).
10. Push the actuator shaft (E) down inside the valve body (4) and remove.
11. Remove and discard actuator shaft o-ring (*D) and actuator shaft bushings (*C). Save the flat washers (B) to reuse.
12. Apply Stem Lube (N*) to the valve body bore and the surface of the actuator shaft (E) that goes up through the the valve body bore.
13. Coat new o-ring (*D) with Stem Lube (N*) and install in groove on actuator shaft (E).
14. Reverse the disassembly procedure (go from 10 back to 1) to install the new parts (*) and reassemble the valve.

Torque requirements;

- Tighten nuts for actuator bracket bolts and actuator bolts (Items 7 & 6) to 140-160 in/lbs.
- Tighten End Cap nuts (M) to 450-550 in/lbs in a criss cross pattern in 120 in/lb increments.