



Hydrant Mounted Monitor Installation Instructions **Models 292-6H, 293-6H, AND 299-11H (750 GPM Max.)**

I. Product Safety



Important: Before installing and operating this equipment, read and study these instructions thoroughly. Proper installation is essential to safe operation. In addition, the following points should be adhered to in order to ensure the safety of equipment and personnel:

- A. All personnel who may be expected to use this equipment must be thoroughly trained in its safe and proper use.
- B. Before flowing water from this device, check that all personnel (fire service and civilian) are out of the stream path. Also, check to make sure stream direction will not cause avoidable property damage.
- C. Become thoroughly familiar with the hydraulic characteristics of this equipment, and the pumping system used to supply it. To produce effective fire streams, operating personnel must be properly trained.
- D. Open water valve supplying this equipment slowly, so that the piping fills slowly, thus preventing possible water hammer occurrence.
- E. After each use, and on a scheduled basis, inspect equipment per instructions in **IV Maintenance and Inspection**.

II. Semi-Permanent Installation

A. Prepare Base

1. Pour concrete slab at base of hydrant as shown in Figure 1. Very soft or wet soil conditions may require larger pad size than specified.
2. Set two eyebolts in wet concrete, 10" from end of hydrant nipple, 8-1/2" apart, with top of eyebolt 3-1/2" above surface of concrete. If a valve is to be installed between hydrant nipple and monitor elbow, adjust 10" dimension to compensate for valve.
3. After concrete has set up, insert the short bent end of threaded rods through eyebolts, and secure with handwheels at position "A".

4. Install handwheels at position “B” on upper ends of support rods.
- B. Assemble Monitor to Hydrant
 5. Set monitor/elbow assembly on support rods by inserting upper ends of rods through holes in ears on either side of elbow. Adjust position of “B” handwheels so that horizontal portion of monitor elbow is square with hydrant barrel, and elbow threaded swivel is in alignment with hydrant nipple.
 6. Thread elbow swivel to hydrant nipple or valve nipple. **To avoid damage to threaded swivel, monitor elbow must be square to hydrant barrel.** Tighten swivel with spanner wrench.
 7. Install remaining two handwheels at position “C” and tighten.
 8. Flow test monitor after concrete has cured.

III. Permanent Installation

- A. Prepare Base
 1. Pour concrete pad per above instructions.
 2. Set short bent ends of threaded rods in wet concrete. Set 4”-6” deep and 9-1/2” from hydrant nipple, and 8-1/2” apart as shown in Figure 2.
- B. Assemble Monitor to Hydrant

Follow Items 5, 6, 7, and 8 in II.B Semi-Permanent Installation.

IV. Maintenance and Inspection

The monitor should be inspected regularly to ensure all functions are operating correctly. Careful inspection for damage to the monitor or nozzle is especially important after use in emergency operations.

Flow water to check nozzle pattern. If pattern is disrupted, remove nozzle and check for debris lodged between the nozzle stem and body, or in the stream shaper inlet.

During nozzle flow test, inspect monitor swivel joints for leaks.

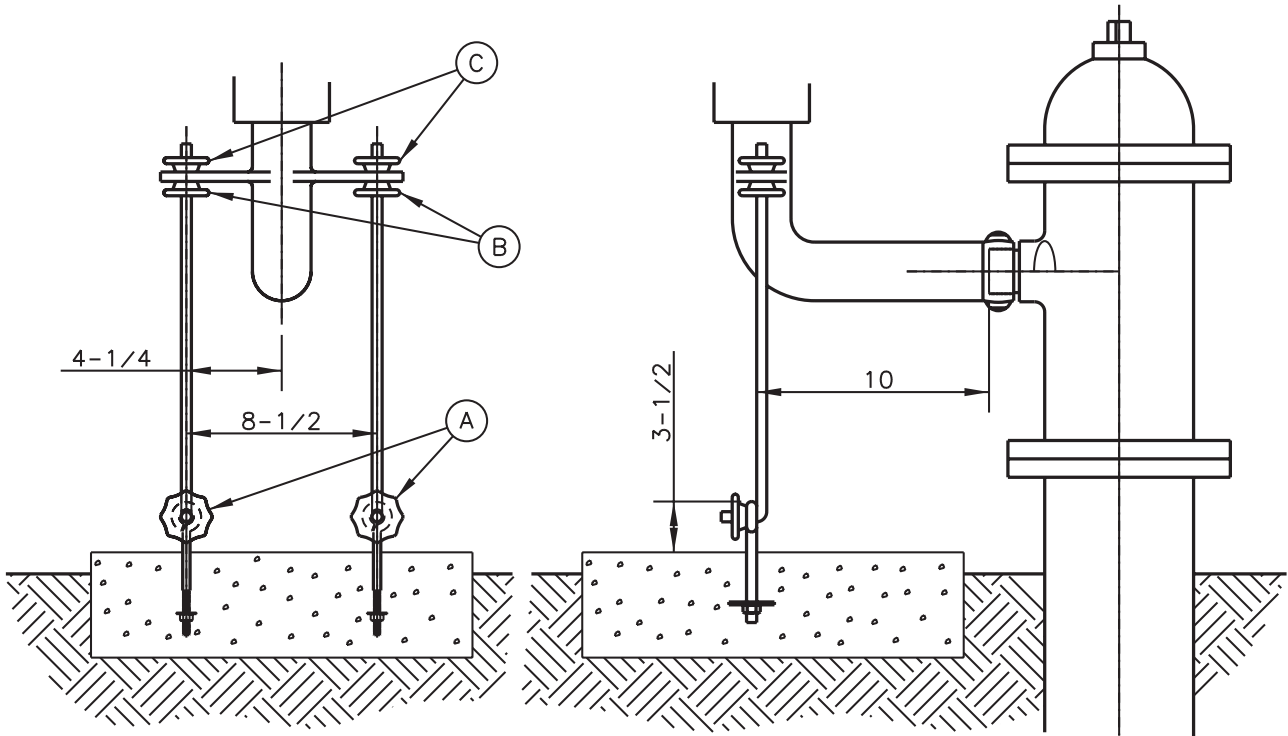

FIGURE I
Semi-Permanent Installation

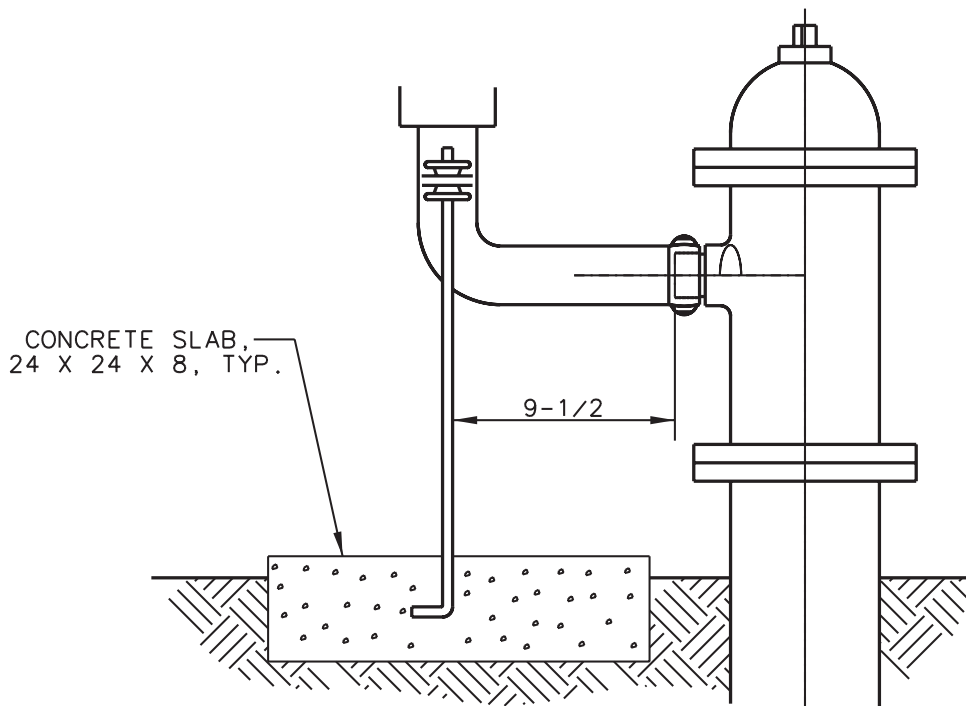

FIGURE II
Permanent Installation